

Full Wrap Around Dimensions

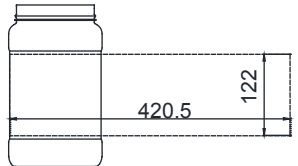

Suggested Label Dimensions

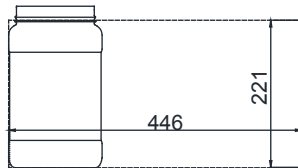

Sleeve Dimensions

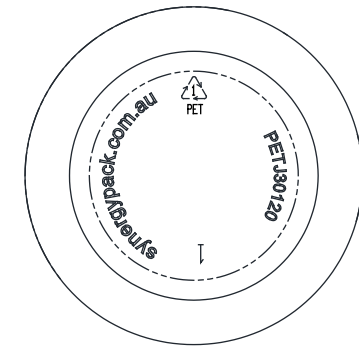
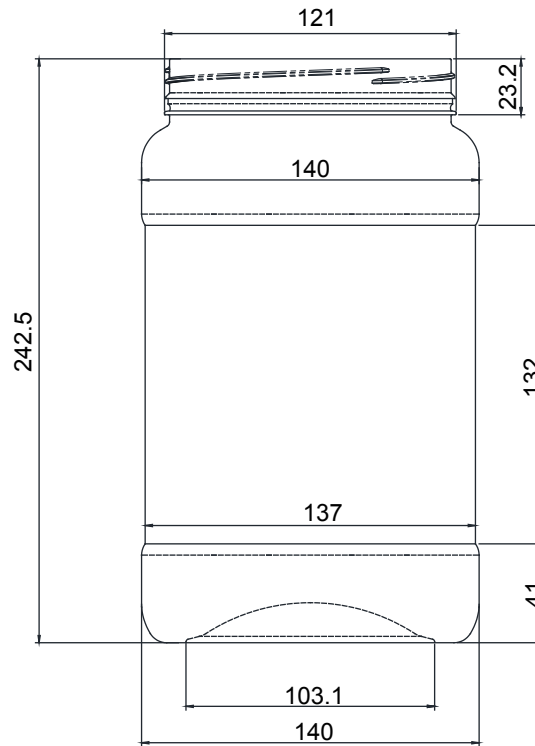

Bottom View

Brimful: 3300±30ml

Height/Lengh	Tolerance
<1	±0.2
>1	±0.4
>5	±0.8
>50	±1.0
>100	±1.6
>200	±2.0
Diameter	Tolerance
<25	±0.4
>25	±0.8
>50	±1.2

Material	PET	Drawing no.	PETJ30120-J120-14-01	Controlled Document	
Weight	145±4g	Description 3L Wide Mouth Jar PETJ30120			
Scale	1:3				
Unit	mm				
Drawn by	A.Song				
Approved by		Synergy Packaging <i>* Customer Copy *</i>			
Revision	Date				Modifications
1	18/11/14				Specification review
0	14/02/13				